



500W ALIS Power Hubs are designed for delivering our patented induction livestock farming platform efficiently, safely and securely



ALIS Power Hub
500W 1-Channel (230V)
Order No: IPH500230



Warranty valid from date of manufacture.



ALIS Power Hub Panel

Benefits to the farmer

- ALIS Power Hubs are at the heart of our proprietary and patented lighting and sensor platform, ALIS, which delivers productivity, environmental and welfare benefits for livestock farmers.
- Installed front of house for safety and improved bio-security.
- Converts mains voltage supply into an efficient and safe High Frequency Alternating Current (HFAC).
- ALIS Power Hubs have a 0.95 Power Factor which can significantly reduce energy bills (see below).

Power Hub features

- ALIS Power Hubs produce clean and safe power for LED lighting with reduced electric shock risk from the 50kHz output.
- ALIS Power Hubs combine very high efficiency with superior reliability and durability.
- Mains voltage stops at the input port of the Power Hub.
- ALIS Power Hubs shut down on interruption of the ALIS Bus lighting cables.
- ALIS Power Hubs act as a circuit breaker and has protection overload.

How a 0.95 Power Factor can reduce your energy bills

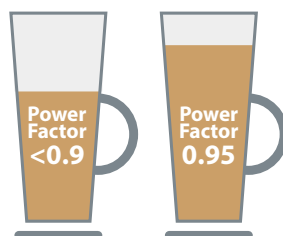

Recent research by Greengage identified that a poultry producer was spending over £60K annually in Reactive Power charges.

Reactive Power (kVar) is necessary to run commercial electrical equipment like our Power Hubs.

Think of commercial energy as a latte coffee, where a Power Factor rating of less than 0.9 creates too much useless froth (Reactive Power), and therefore additional utility charges.

Our ALIS Power Hubs have a Power Factor of 0.95 which produces the optimum amount of 'froth' (Reactive Power) with zero or minimal kVar charges.

Power Hub Panels for additional benefits and features

Power Hubs can be enclosed in panels (opposite) for additional protection, safety and security.

A switch for ALIS Blue Lamps and ventilated panels are also available.

ALS0006 – ALIS Power Hub Panel 500w, 2 Channel SU

ALS0010 – ALIS Power Hub Panel 500w, 1 Channel SU

Input specifications

Parameter	Description	Measurement
VAC RMS	Input supply	Nominal 230V
Frequency	AC RMS (Hz)	Nominal 50Hz
Input current	AC RMS (I)	Nominal 3.7Amps
PFC*	500W Output	Nominal 0.984
THD*	500W Output	Nominal 2.4%

*PFC: Power Factor Correction. THD: Total Harmonic Distortion.

Environmental specifications

Parameter	Description	Measurement
Operating temperature	Thermal environment	Min 10°C Max 40°C
Operating humidity	Non condensing	Min 0% Max 85%
Altitude operating		10,000ft (3048m)
IP rating (indoor use only)		IP10, NEMA Type 1

Efficiency

Parameter	Description	Measurement
Efficiency (note 2).	500W	Nominal 95%

Note 2: Meets the European code of conduct for energy efficiency level 4.

500W dimensions (mm) L 340 x W 206 x H 82

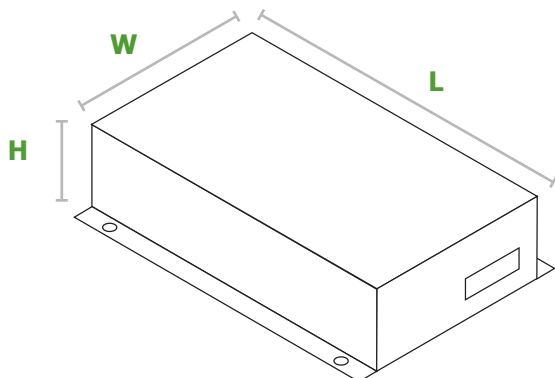

Protection and status indicator

- To facilitate fault diagnosis, the PH500 has a bi-colour (red and green) status indicator. Please read the installation manual available to download at our website www.greengage.global/downloads

System installation calculations

- Absolute maximum power on ALIS BUS cable length is 475W
- ALIS BUS cable losses 12W per 100M length
- NOTE: Does not apply to 120V units, see PH500-120V Data Sheet for data on 120V Unit.

Power Calculation Example

- PH500 with 100M ALIS BUS - Cable losses = 12W.
- 500 W - 12W = 463 W available power for LED Loads.
- Install 46 luminaries at 10W each (460W Load).
- 460W + 12W = Total power demand 472W.

Output specifications

Parameter	Description	Measurement
Power rating	Maximum Power	Max 500
OP Frequency	AC Bus frequency	Nom 50kHz
O/P Current	Bus loop current (rms)	Nom 1.9A

Technical specifications

Weight (200W / 500W)	1kg / 3kg
Dimmer option	100K potentiometer or 0-10V.

Compliance

This equipment complies with EMC Directive 2017/30/EC and LVD directive 2014/35/EC. Demonstrated by meeting the following standards

Standard

EN55015:2013 + A1:2015
EN61547:2009
EN61000-3-2:2014
EN61000-3-3:2013
EN62493:2015
EN61347-1:2015
EN61347-2-13:2014 + A1:2017

Approvals and certifications



ALIS Power Hubs are an essential component of our patented ALIS platform



DTD Controller



ALIS Barn Lamp



ALIS Blue Lamp



ALIS Tube Lamps



ALIS Nest Lamp



ALIS Sensors

Low shock hazard

The unique features of the system make it inherently safe.

- The PH500 acts as a circuit breaker and RCD.
- If the ALIS Bus cable is cut, the Output Over-voltage protection is instantly activated and the Power Hub switches off.

If the insulation of the ALIS Bus cable is breached and makes contact with conducting material, the Power Hub detects a ground fault and switches off. Power is extracted from the ALIS Bus without breaking into the cable's insulation (see ALIS Couplers).

- Both PH200 and PH500 have outputs isolated from Mains AC by double/reinforced insulation.
- The output is balanced about earth in the same way as a safety isolation transformer.
- The average voltage of the ALIS is the chassis voltage of the hub, in effect local PE.

To view our patent information visit: www.greengage.global/patents